

# INSTALLATION INSTRUCTIONS



# Energy Manager

Keep these instructions with the boiler at all times for  
future reference

BOYERTOWN FURNACE CO.  
PO Box 100  
BOYERTOWN, PA 19512  
1-610-369-1450

[www.boyertownfurnace.com](http://www.boyertownfurnace.com)

2-12-07

## Be Aware of Hazard Definitions

### **Danger**

Denotes presence of a hazard which, if ignored, will result in severe personal injury, death or property damage

### **Warning**

Denotes presence of a hazard which, if ignored could result in severe personal injury, death or substantial property damage.

### **Caution**

Denotes the presence of a hazard, which if ignored, could result in minor personal injury or property damage

### **Notice**

Intended to bring attention to information, but not related to personal injury or property damage.

### **Danger**

This equipment must be installed, adjusted, serviced and started only by a qualified service agency – an individual or agency, licensed and experienced with all codes and ordinances, and who is responsible for the installation and adjustment of the equipment. The installation must comply with all local codes and ordinances and with the latest revision of the National Fire Protection Standard for Oil Burning Equipment, NFPA 31.

Read all instructions before proceeding. Follow all instructions completely. Failure to follow these instructions could result in equipment malfunction causing severe personal injury, death or substantial property damage.

Do not alter this kit or the boiler in any way. The manufacturer will not be liable for any damage resulting from changes made in the field to the boiler or its components or from improper installation. Failure to comply could result in severe personal injury, death, or substantial property damage.

Your oil fired boiler is designed to burn No. 1 and No. 2 heating oil only. Never use gasoline or a mixture of gasoline and oil.

Do not store gasoline or other flammable vapors and liquids in the vicinity of this or any other appliance.

The area around the boiler should be kept free and clear of combustible materials.

Never burn garbage or refuse in your boiler.

Never try to ignite oil by tossing burning papers or other material into your boiler.

Do not attempt to start the burner when excess oil has accumulated or the boiler is full of vapors.

Do not operate boiler if the heat exchanger is damaged.

Do not jumper, attempt to bypass or override any of the safety limit controls.

Do not use this boiler if any part has been under water. Immediately call a qualified service technician to inspect the boiler and replace any part of the boiler, control system or burner that has been under water.

All installations must conform to the requirements of the authority having jurisdiction. Such applicable requirements take precedence over the general instructions of this manual.

Where required by the authority having jurisdiction, the installation must conform to the American Society of Mechanical Engineers Safety Code for Controls and Safety Devices for Automatically Fired Boilers, ANSI/ASME CSD-1.

### **Notice**

Concealed Damage- If you discover damage to the burner, boiler or controls during unpacking, notify the carrier at once and file the appropriate claim. When calling or writing about the boiler please have the following information available: The boiler model number and serial number.

## **Table of Contents**

Operational Theory.....	4
Installing the Energy Manager to the Boiler.....	5
Aquastat Installation.....	5
Primary Water Sensor Installation. ....	6
Domestic Water Sensor Installation.....	7
Wiring.....	7
System Check Out.....	9
Control Circuit Safety Checks .....	9
Trouble Shooting .....	10

## Operational Theory

The Trio Energy Manager adjusts the burner firing pattern to accurately match the boiler output of the homes heat load.

The boiler and your heating systems are designed to ensure comfort at outdoor temperatures well below the average winter temperatures. At any temperature warmer than the coldest design temperature, the boiler is able to provide more heat than the home requires. The result is that the burner cycles on and off many times per hour to keep the home from overheating. This repeated on/off cycling is a very inefficient way for the boiler system to operate.

The HeatManager uses a single temperature sensor attached to the boiler supply pipe to measure both heat load and boiler water temperature. Every time the burner shuts off the supply mounted sensor takes 3 readings per second and transmits them back to the heat manager. The heat manager then determines the heat load by analyzing the temperature drop off rate during the burner off cycle.

After determining the heat load, the HeatManager uses a patented algorithm to determine the minimum boiler water temperature needed to maintain comfort at the measured heat load. Energy savings which are derived from maintaining the optimal boiler temperature include reduced average flue gas temperatures, reduced off cycle flue losses, reduced distribution losses, reduced pre/post purge losses and improved burner life.

There has been substantial testing done to validate the energy savings by Brookhaven National Laboratory and Atlantic Testing Laboratory. Their test results show burner run time is reduced by 10% – 20 % and the number of burner on/off cycles is reduced by 30%.

After installation, setting the power switch on Trio Energy Manager to the “On” position and the HeatManager to the “On” position activates the control. Three green lights on the HeatManager indicate normal operation and will sequence as the device goes through its operating cycle. Each green light indicates one of three possible modes of the HeatManager’s operation which are “Standby”, “Economizing” and “Burner Enabled”. In the “Standby” mode the boiler is operating under the control of the aquastat which has the burner turned off. In the “Economizing” mode the boiler aquastat has requested that the burner be turned on but the HeatManager has sensed that there is available heat in the boiler which can be used without turning on the burner. The burner will remain off until all of the useful heat has been utilized from the boiler. In the “Burner Enabled” mode the burner is running.

The additional three status lights on the Trio Energy Manager indicate that the low water cut off is enabled and functioning properly, that a call for heat has been established and that the burner has been energized. See Figure 1 for the location of lights and switches.

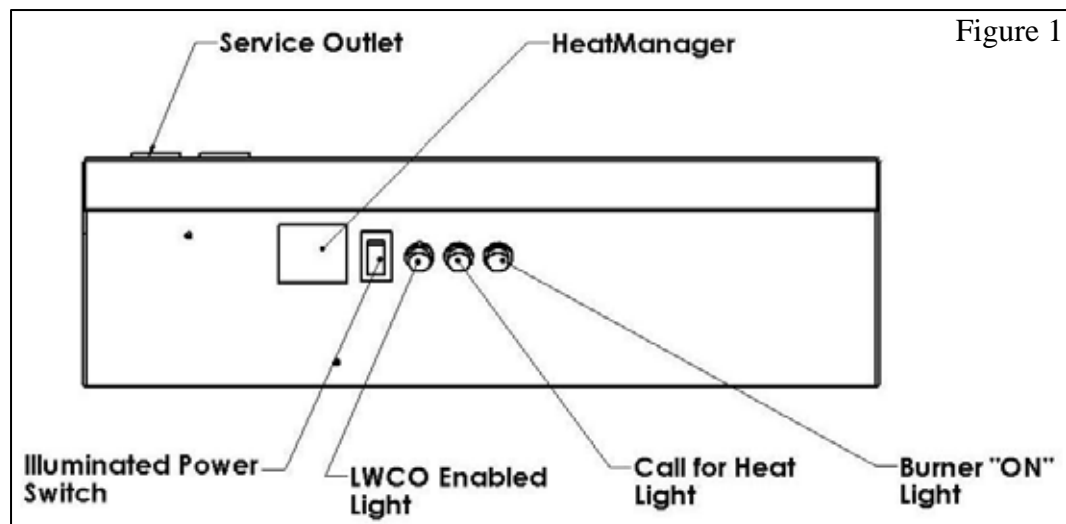

## Installing The Trio Energy Manager To The Boiler

1. Lift and remove the jacket front panel.
2. Remove the two 7/8" knockouts in the jacket top panel. Note these are double tabbed knockouts which must be removed by bending opposite the tabs.
3. Remove the lower lock nuts from the box connectors located on the Trio Energy Manager.
4. Insert the box connectors through the 7/8" hole in the jacket top panel. Thread on the lock nuts to the box connector and tighten.

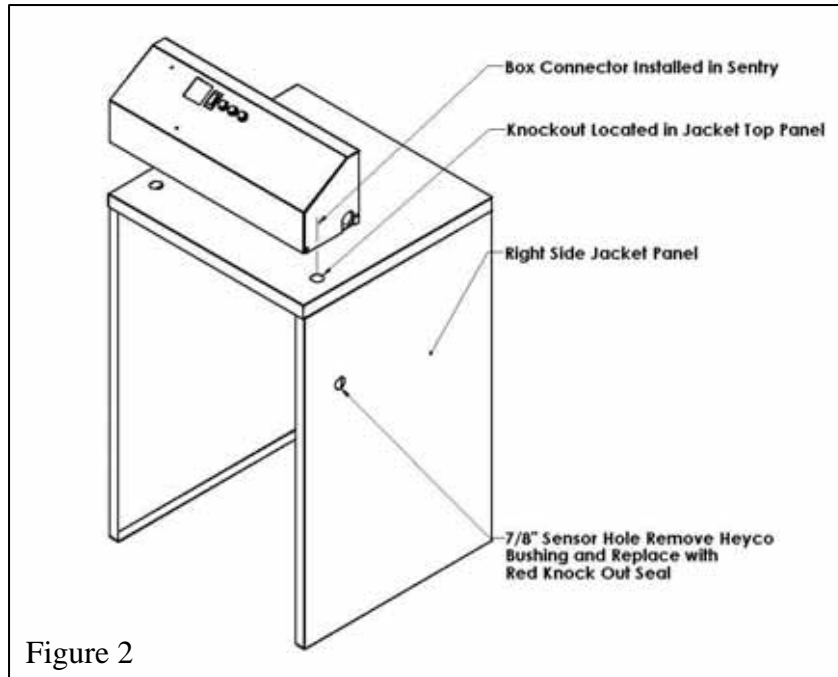

## Aquastat Installation

1. Remove the aquastat from the burner box.
2. Open the Trio Energy Manager box by removing only the two rear 10-32 hex washer head screws and pivoting the box top forward on the front two 10-32 hex washer head screws. See Figure 3.
3. Install the aquastat on the base using the 10-32 hex washer head screws provided. See Figure 4 for screw hole locations for the Honeywell Aquastat.
4. Install the Heyco bushings into the aquastat knockouts to prevent damage to the wires.
5. Remove the aquastat sensor wires which are running through the side of the jacket and feed them through the box connector of the Trio Energy Manager and attach to the aquastat.

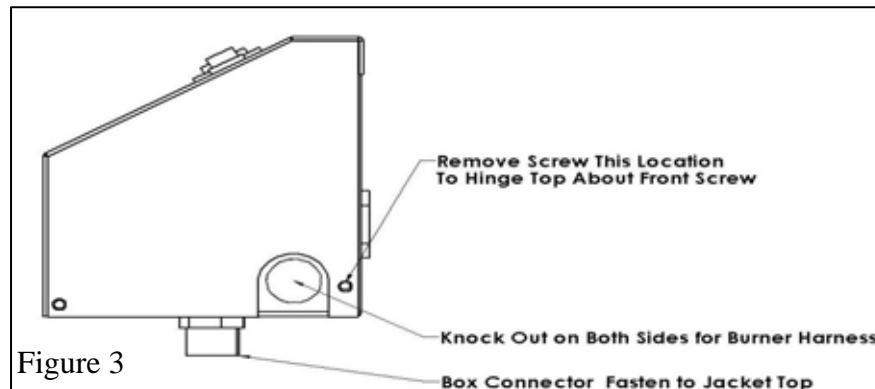

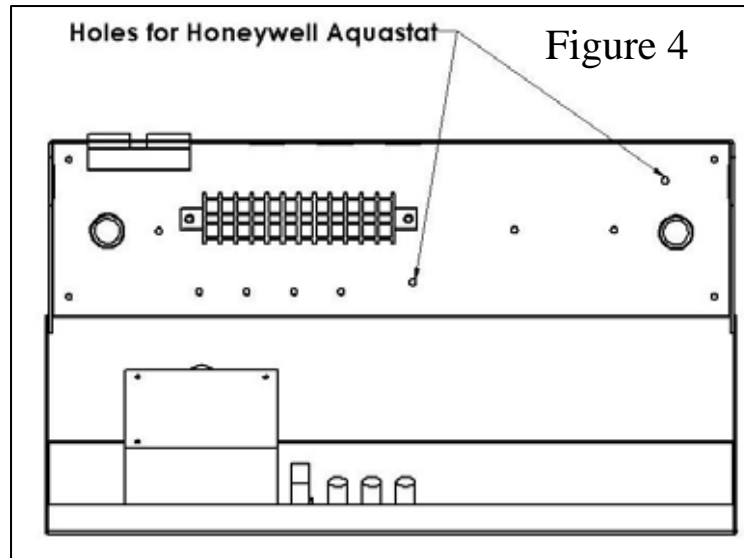

### Heat Manager Primary Water Sensor Installation

1. Route the sensor wire through one of the box connectors in the Trio Energy Manager, under the jacket top and through the Heyco bushings which are inserted in jacket top brackets. These brackets also carry the Aquastat sensor to the back of the boiler.
2. Attach the HeatManager sensor to the boiler supply pipe as close to the boiler as possible preferably on the 1-1/2" x 3" nipple inserted directly into the rear boiler section using the wire ties provided. Make sure that the sensor makes good thermal contact with the pipe. See Figures Below.
3. Cover the sensor with a piece of insulation and tape in place. See Figure 5.

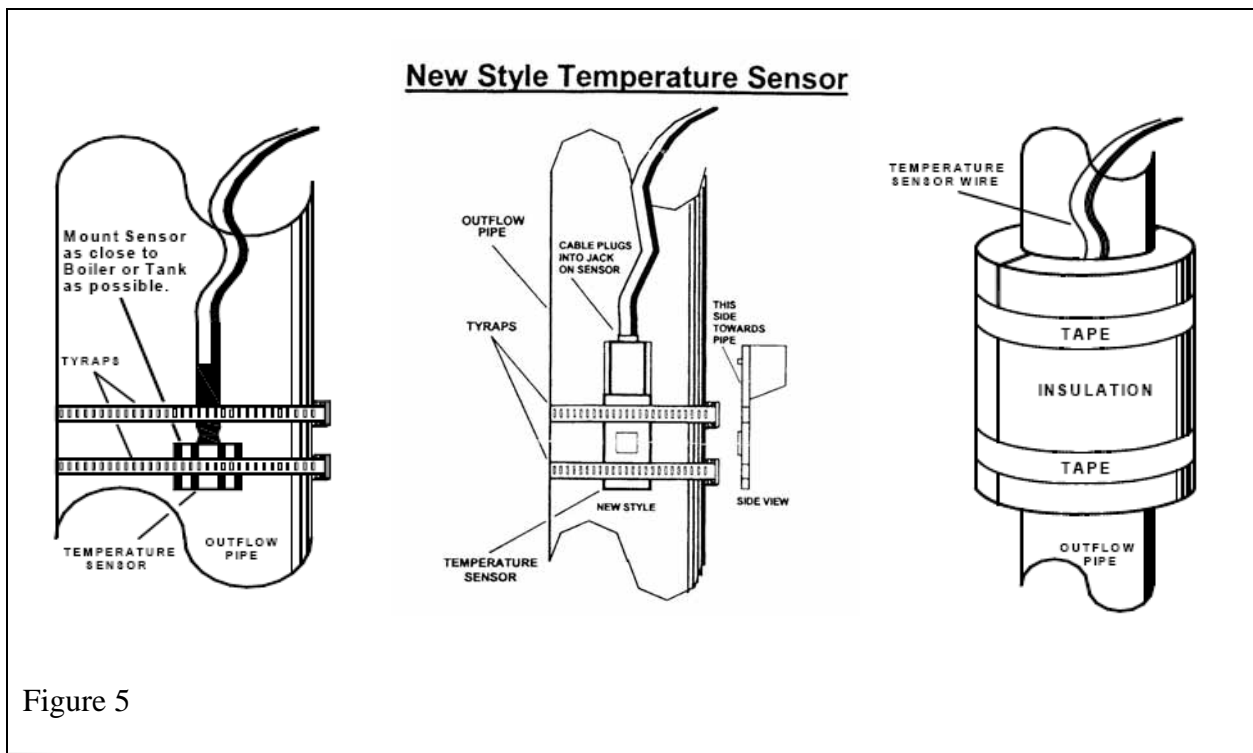

## **Heat Manager Domestic Water Sensor**

The purpose of the second sensor is to detect a drop in the temperature of the domestic hot water. If it detects a drop in temperature it will override the economizing mode and allow the burner to fire if there is a call for heat already established.

This sensor is typically not required when using an indirect hot water heater. The indirect water heater functions just like any other zone in the heating system. When more domestic hot water is required, the indirect water heater will call for heat. The heat manager will detect this heat load demand through its standard sensor that is installed on the boiler supply pipe.

## **Electrical Wiring**

**Danger** Electrical Wiring Must Conform to The National Electrical Code, ANSI/NFPA and Local Codes.

The boiler must be electrically grounded and on a separate fused disconnect switch.

Electrical shock is hazardous. Turn off all power supplies before starting to make any wiring connections or repairs.

Refer to wiring diagrams in this manual for electrical connections. The boiler should be connected to a separate, electrical supply circuit with a minimum 15 amp fused rating. Use No. 14 AWG wires rated for at least 90° C. Install a separate fused disconnect or safety switch near the boiler so all power can be shut off for servicing.

Caution: Label all wires prior to disconnection when servicing controls. Wiring errors can cause improper and dangerous operation. Verify proper operation after servicing.

1. Install the burner wiring harness supplied with the Trio Energy Manager into the knockout on the side opposite of the burner door hinges. The 26" long harness supplied is for the Riello Burner. When using with a Beckett burner harness length needs to be reduced to approximately 9" by removing the 90° connector and cutting only the BX to length. Reinstall the 90° connector. When properly installed the burner swing door should not be able to be opened beyond a safe distance without separating the Molex plug connection.
2. Wire the incoming power to the Trio Energy Manager as indicated in the wiring diagrams providing overload and disconnect means as required by code.
3. Wire the Low Water Cut Off into the control circuit. Refer to the Low Water Cut Off manufacturer's instructions for wiring of LWCO switch into the Trio Energy Manager control circuit.
4. Install the room thermostat on an inside wall away from fireplaces, appliances or sunlight. Set the heat anticipator according to the instructions from the aquastat manufacturer. Connect the thermostat leads to the "TT" connections on the aquastat control or system control.
5. The indirect water heater, if used, may be wired in such a fashion that the indirect water heater has priority over the building heat. Commercially available circulator prioritizing packages are available.



## **System Checkout**

1. Recheck all wiring connections.
2. Verify the proper installation of the HeatManager sensor to the boiler supply piping and that it is plugged into the proper jack(s).
3. Set the HeatManager switch to the Off/Bypass.
4. Restore power to the Trio Energy Manager and turn the “Power Switch” to the on position as indicated by the illuminated switch.
5. To ensure the maximum savings, adjust the aquastat high limit set point temperature to a minimum of 170°F.
6. Set the HeatManager switch to the “On” position. The HeatManager will now go through a self test process. After the sensor test one of the green lights will activate depending upon the temperature of the boiler.
7. If the HeatManager comes on and goes into the “Standby Mode”, force a call for heat by turning up the thermostat and verifying the change in the mode of the HeatManager to either “Economizing” or “Burner Enabled”.
8. If the boiler water temperature is already below 145°F when a call for heat is established, the HeatManager will go into the “Burner Enabled” mode and the burner will immediately start. When this happens, the red low temperature limit light will turn on along with the green burner enabled light. The red light will stay on through the duration of the burner on cycle.

## **Control Circuit Safety Checks**

Check the safety controls on the boiler after completing the oil burner adjustments. A safety control check for satisfactory performance must be performed.

1. High limit control - Remove the aquastat control cover as needed and note temperature setting. With the burner running reduce the high limit setting until the burner shuts off. Return the high limit to its original setting.
2. With the oil burner running verify proper operation of the low water cut off. Refer to the instructions provided by the low water cut off manufacturer for testing of the low water cut off. The oil burner should shut off when the low water cut off is functioning properly.
3. To check the primary control and flame sensor shut off oil supply with hand valve while burner is running, fifteen seconds after flameout, the safety switch locks out, ignition stops and the oil valve should close. To restart, open oil supply valve and reset safety switch.

# Trouble Shooting Guide

Burner Will Not Start

