



CAST IRON BOILERS





CAST IRON BOILERS



The **TRIO** by PurePro® addresses your three most common concerns when choosing a boiler:

- ▶ Efficiency
- ▶ Longevity
- ▶ Environment

The TRIO is the result of 50 years of engineering and manufacturing experience. With its low mass design and efficiencies up to 87% AFUE, TRIO addresses growing concerns about fuel prices. Recirculating flue gas technology reduces fuel emissions and sets the standard for environmental integrity. The TRIO is constructed of GG20 cast iron for greater durability and thermal shock protection.

This is one of those times when you can get exactly what you want. . . exceptional value, technology, efficiency, and performance.

With a heritage dating back to 1866, PurePro® has earned the approval of Professional Contractors for quality, value, and reliability.



A Blend of Technology and Efficiency

The TRIO is a low mass boiler with steel push nipples. The unique turn-around design of the rear casting creates optimal flue gas passages through the boiler, creating high efficiency. There are no baffles to remove, and the flue passages are easily accessible for cleaning and servicing. The TRIO boiler is Energy Star rated with efficiencies to 87%.



Shown with Riello Burner and PurePro® Energy Manager Plus II.

Features:

- ▶ 3-pass low mass design
- ▶ GG20 cast iron
- ▶ Recirculating flue gas technology
- ▶ Energy Star Rated 
- ▶ High efficiency to 87%
- ▶ Superior serviceability with complete access to all flue passages
- ▶ Limited Lifetime Warranty
- ▶ Direct vent capabilities

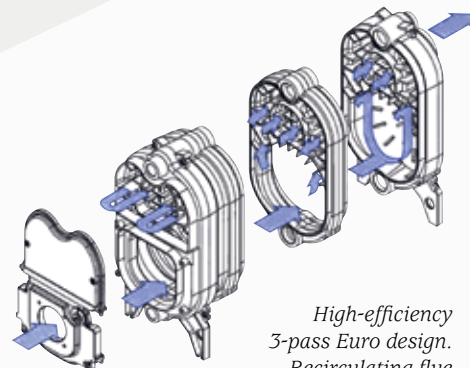

High-efficiency 3-pass Euro design. Recirculating flue gas technology.

Maximize System Efficiency With the PurePro® Energy Manager Plus II

Features:

- Operates circulators or zone valves or a combination of both
- An integrated 75VA low voltage transformer is included to power zone valves
- Illuminated power switch and ground fault receptacle
- Color coded green Molex® connector for system circulator when using zone valves
- Color coded white Molex® connector for use with the PurePro® Plug n' Go indirect heater
- Color coded blue Molex® connector for domestic hot water circulator (when a Plug n' Go tank is not used)
- Terminal strip for easy field wiring of power supply
- Hydrolevel 3250 control LED status lights: Boiler temperature display, low water cut off
- Expandable zone module allows for the addition of four additional zones using either zone valves or circulators independent of original module configuration



- Selectable domestic hot water priority, selectable off or priority with 30 minute override
- Boiler heat post purge - 30 seconds
- Pump/valve exercise - 30 seconds per two weeks of space heating inactivity
- Freeze protection
- Boiler supply and return sensors
- Status lights from the AQ25042B (visible from top, side or front of unit): ZR terminal active, boiler active, domestic water active, auxiliary output active, active zone lights
- Auto test capabilities for ease of trouble shooting and system purging

See trioboiler.com for details.

Abundant, Rapid Hot Water Heating

PurePro® offers a complete line of indirect water heaters to complement the TRIO boiler. By utilizing the TRIO boiler as its heat supply, the burner fires only when necessary and transfers heat from the TRIO boiler to the water heater through a highly efficient heat exchanger.



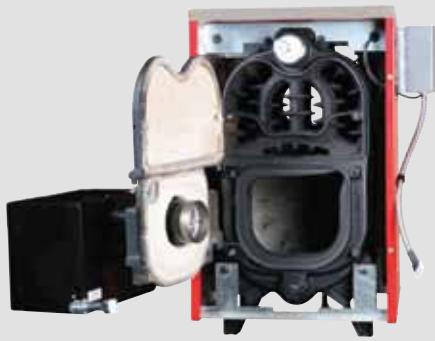

A unique front jacket panel designed for easy removal allows convenient access to a one-piece swing-out door. The door is both easily opened and completely removable from the vessel for internal inspection and overall maintenance. The TRIO boiler features oil and gas burners with a quick disconnect for servicing.



*Direct Vent Only: Models P3, P4, P5
**Energy Star rated

SPECIFICATIONS									
PurePro Boiler Model #	Firing Rate (#2 Fuel)	PurePro Burner Model #	Burner	Input (btu/hr)	DOE Capacity (btu/hr)	NET IBR (btu/hr)	Net Rating (Sq. ft.)	AFUE Rating	Water Capacity
P3	0.75	707719 707724 707740 707730 705551	Riello F3 Riello BF5* Beckett AFG Beckett NX Carlin EZ	105,000	91,000	79,000	526	85.5**	3.6
	Gas	708840 708841	Carlin EZ Natural Gas Carlin EZ LP Gas						
P4	1.00	707721 707724 707741 707731 705551	Riello F5 Riello BF5* Beckett AFG Beckett NX Carlin EZ	140,000	122,000	106,000	707	86.5**	4.3
	Gas	708842 708843	Carlin EZ Natural Gas Carlin EZ LP Gas						
P5	1.25	707722 707724 707732 705551	Riello F5 Riello BF5* Beckett NX Carlin EZ	175,000	153,000	133,000	887	86.9**	5.1
	Gas	708844 708845	Carlin EZ Natural Gas Carlin EZ LP Gas						
P6	1.50	707723 707733 705551	Riello F5 Beckett NX Carlin EZ	210,000	184,000	160,000	1067	86.9**	5.8
P7	1.75	707734	Beckett CF375	245,000	208,250	181,100	1207	85.0**	6.5

DIMENSIONS							
PurePro #	Cabinet Height	Cabinet Width	Cabinet Length	Supply Outlet Height C.L.	Return Outlet Height C.L.	Flue Outlet Diameter	Flue Outlet Height C.L.
P3	28-7/8"	17-3/4"	19-1/4"	25-3/8"	4-1/2"	6"	20-3/4"
P4	28-7/8"	17-3/4"	22-3/4"	25-3/8"	4-1/2"	6"	20-3/4"
P5	28-7/8"	17-3/4"	26-1/4"	25-3/8"	4-1/2"	6"	20-3/4"
P6	28-7/8"	17-3/4"	29-3/4"	25-3/8"	4-1/2"	6"	20-3/4"
P7	28-7/8"	17-3/4"	33-1/4"	25-3/8"	4-1/2"	6"	20-3/4"

ONE STEP
CLOSER
TO
GREEN!



Available Oil/Gas Burners



CAST IRON BOILERS

by

PurePro

trioboiler.com

PPRH30/1000/212